

8

7

6

5

4

3

2

1

D

C

B

A

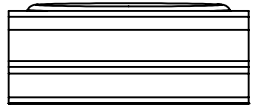
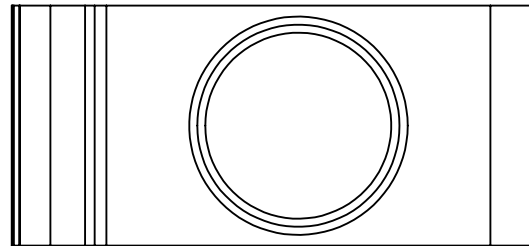
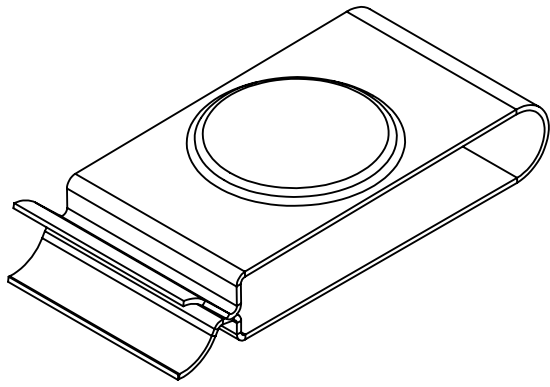

2.73

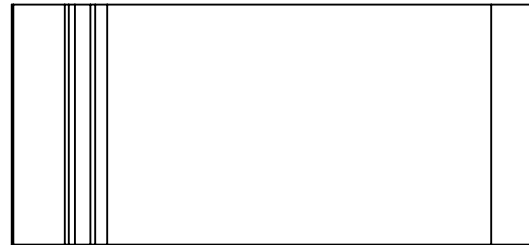

.44

1.25

MATERIAL MAT'L. SPEC.		UNLESS OTHERWISE SPECIFIED DIMENSIONS ARE IN INCHES. TOLERANCES ARE: FRACTION DECIMAL ANGLE + - 1/64 .XX + - .010 + - 1 .XXX + - .005		THE CLIP.com <i>Device Portability Experts</i>	
FINISH BLACK POWDER COAT		APPROVED DRAWN D. E. STEIN	DATE 10/16/2016		
SIMILAR TO P/N		CHECKED D. E. STEIN	10/16/2016	SCALE 1:1	SHEET 1 OF 1

8

7

6

5

4

3

2

1